



CARMAR ACCURACY CO., LTD.

Linear Gauge

- **Suitable for a variety of industrial automation;
High-accuracy dimension, displacement,
thickness measurement**
- **Exchangeable probe-head;
Operable in harsh environments**



Made in Taiwan

■ AREA OF APPLICATIONS

1. Free surface
2. Warpage
3. Thickness
4. Shaft slants
5. Mold critical dimensions
6. Spindle travel distance
7. Camshaft profiling
8. Sheet-metal probing in auto-industry
9. Structure displacement monitoring
10. Process quality control

■ SAMPLE APPLICATIONS

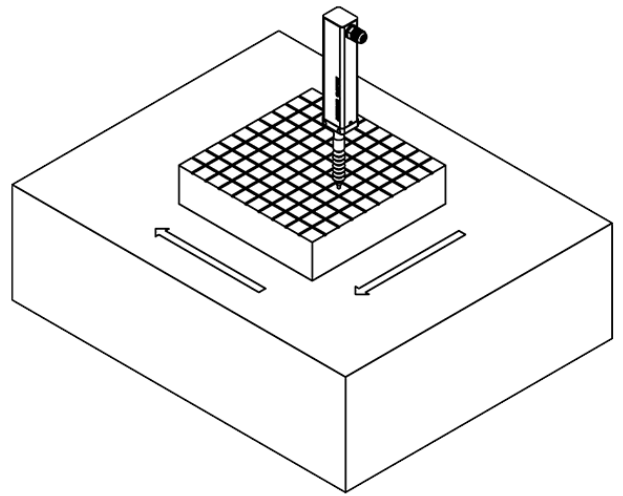
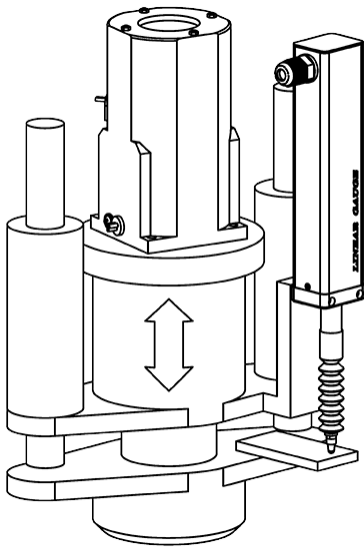

Travel calibration & compensation
for PCB drilling machine spindles

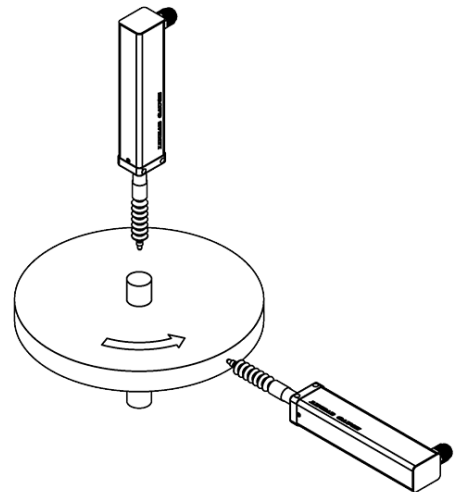
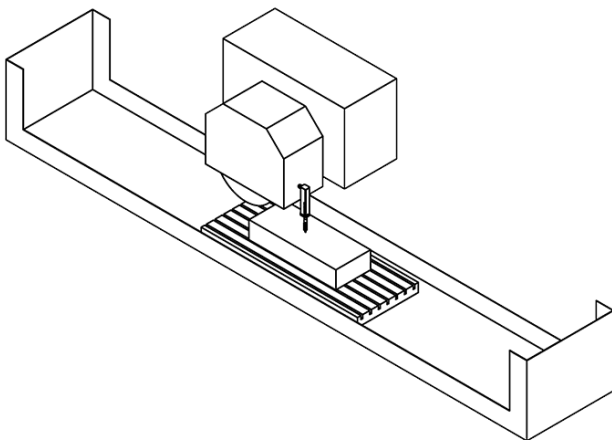

Free surface checkup



Feed control for grinding wheel

Cam waviness and runout

■ SPECIFICATIONS

Model	Digital : DLG	Analog : ALG
Resolution*	0.1 μm / 0.2μm / 0.5 μm / 1 μm / 5 μm	—
Signal period	4-fold the resolution	Grating period 20 μm
Travel	25 mm / 30 mm	
Accuracy (@ 20°C)	± 3 μm / ± 5 μm	
Meas. Force	< 5 N	
Measuring Speed (max.)	400 mm / s	
Guaranteed travels	> 10 million times	
IP grade	IP 54 / IP 67	
Stem diameter	φ 5.0 mm	
Probe-head thread	M 2.5 × 0.45 p	
Input voltage	5.0 Vdc ± 5 %	
Operation current	Digital : ≤ 70 mA (@ 5 Vdc) Analog : ≤ 55 mA (@ 5 Vdc)	
Operation temperature	0 ~ +50 °C	
Storage temperature	-10 ~ +55 °C	
Output signal	Digital : A / B phase differential  (RS422) Analog : A / B phase differential  (1 Vpp)	
Cable length	≈ 2 m, or customized (≤ 10 m)	
Mass (with cable)	25 mm : ≈ 330 g / 30 mm : ≈ 350 g	

- ◆ A four-fold increase of the signal period. Refer to output signals on the next page.
- ◆ Models and specs may change without notice. Accuracy good for downward measurement.

■ OUTPUT SIGNALS

Differential \square (RS422)

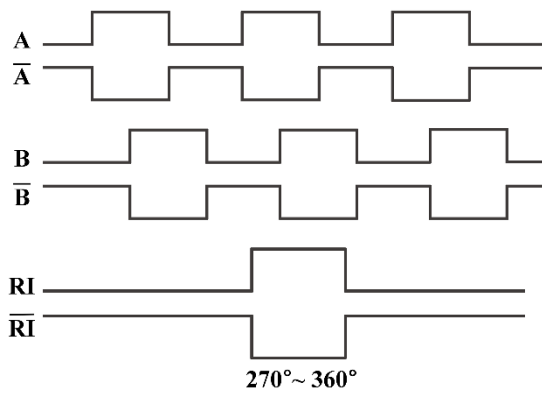

Differential \sim (1 Vpp)

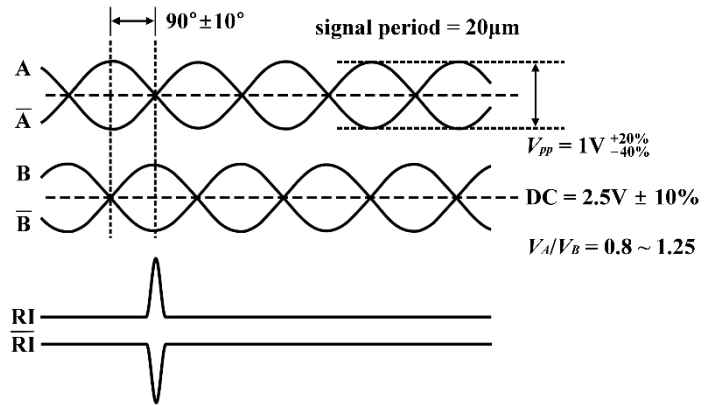

■ INTERFACE CIRCUIT ALTERNATIVES

Square-wave signal output (RS422) interface circuit

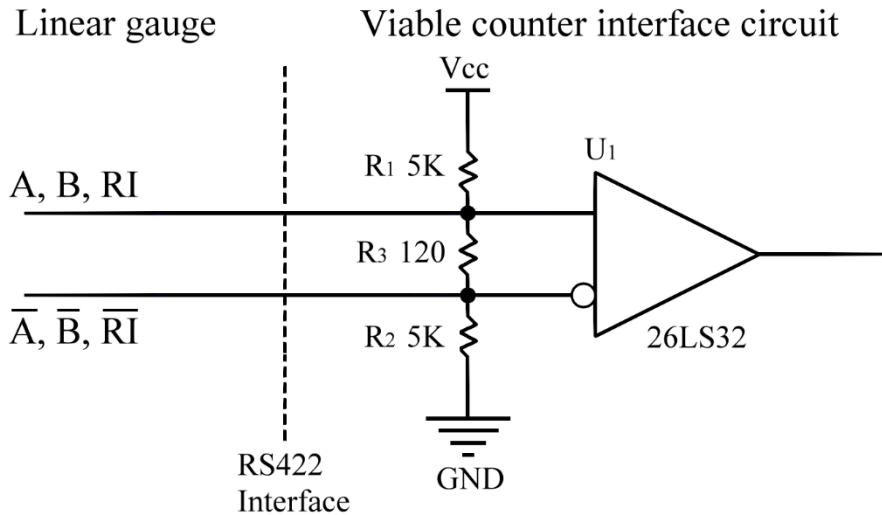

Sinusoidal signal output interface circuit

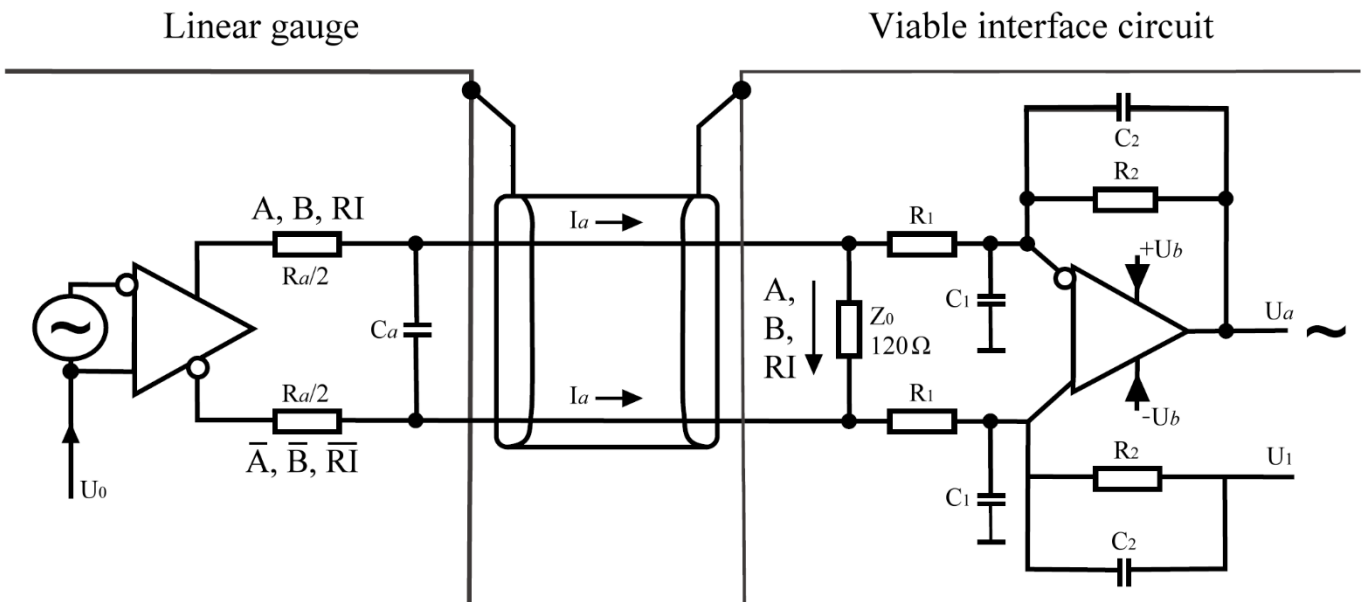

25 series



30 series



■ SPECIAL FEATURES



- High-accuracy dimension, displacement, thickness measurement
- Low measuring force, high stability, low noise
- Exchangeable probe-head; easy operation and installation
- Protection against dust, splash, coolant, oil, etc.; used in harsh environments, and along with cooling system

DIMENSIONS (in mm)

25 series

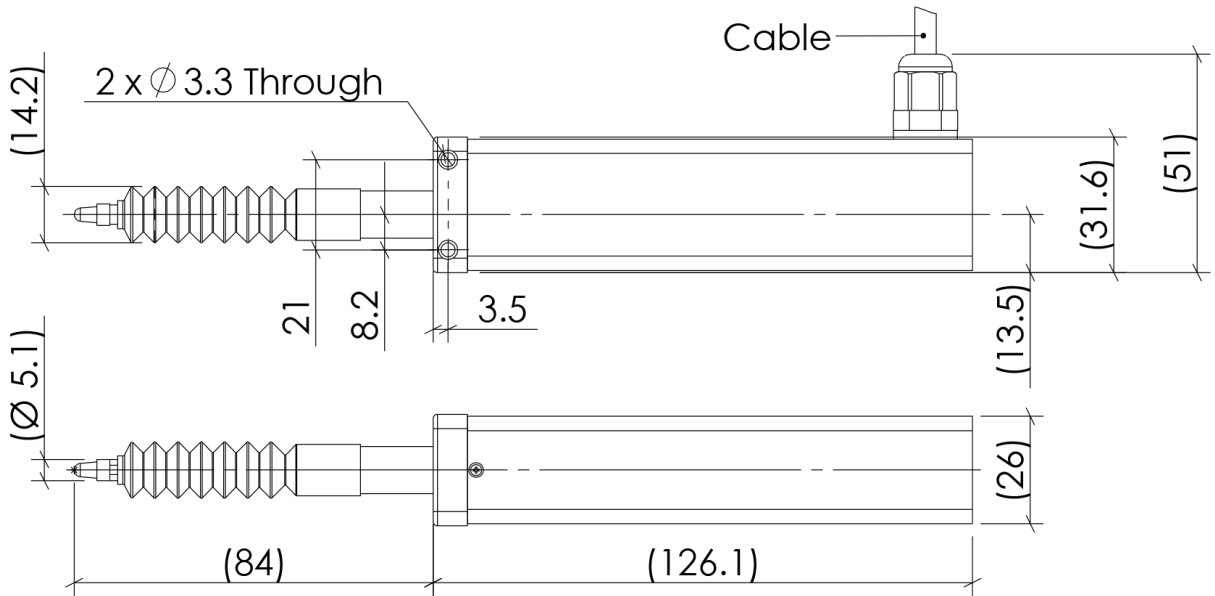

30 series

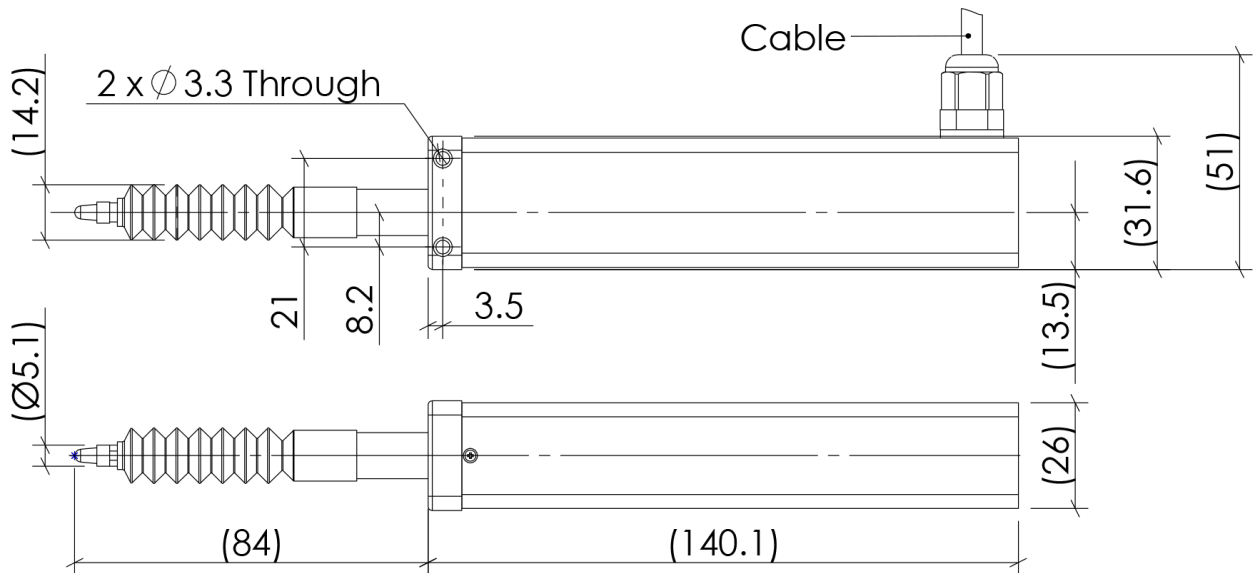

■ MODEL NUMBER CODING

$\frac{\text{DLG}}{\textcircled{1}} \quad \frac{25\text{A}}{\textcircled{2}} - \frac{10}{\textcircled{3}} - \frac{\text{N}}{\textcircled{4}} \quad \frac{\text{D}}{\textcircled{5}} \quad \frac{20}{\textcircled{6}} \quad \frac{\text{A}}{\textcircled{7}}$

Model number coding			
①	Series name	DLG : Digital	ALG : Analog
②	Travel	25A / 30A : 25mm / 30mm	
③	Resolution / Grating period	01 : 0.1 μm 10 : 1 μm 02 : 0.2 μm 50 : 5 μm 05 : 0.5 μm	Grating period 20 μm
④	Reference index (RI)	N : without RI	R : with RI
⑤	Connector type	D : D-Sub9 E : D-Sub15 (VGA)	F : D-Sub15 (customized) N : bare wires (customized) S : guest supply (customized)
⑥	Cable length	05 : 0.5 m 15 : 1.5 m 10 : 1 m 20 : 2 m (standard)	S : ≤ 10 m (customized)
⑦	IP grade	A : IP67	B : IP54

■ PIN ASSIGNMENT

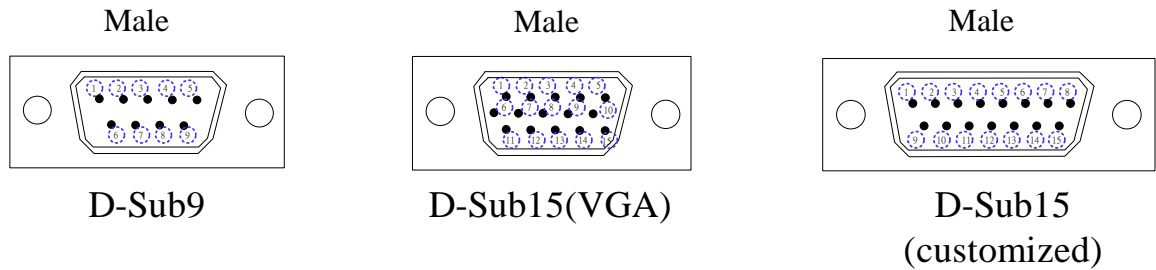

Differential (male connector)									
Assignment	+5V	0V	A+	B+	RI+	RI-	A-	B-	Shield
D-Sub9	1	2	3	4	5	6	7	8	
D-Sub15	1	2	3	4	15	5	13	14	

* Shield means external shielding line / case ; 0 V means 0 Vdc / internal shielding line.



CARMAR ACCURACY CO., LTD.

Tel : +886-4-23592289 **Fax :** +886-4-23598060

E-mail : royal@carmar-tech.com

Add : No. 6, 23rd Road, Industrial Park,
Taichung City 40850, Taiwan



www.carmar-tech.com